



# Datasheet

---

Total MIPI Display IP Solution

DSI v1.3 Host Controller  
DSI v1.3 Device Controller  
D-PHY v1.2 Physical Interface

Arasan Chip Systems Inc.

2010 North First Street, Suite #510, San Jose, CA 95131

Ph: 408-282-1600

Fax: 408-282-7800

[www.arasan.com](http://www.arasan.com)

## Disclaimer

This document is written in good faith with the intent to assist the readers in the use of the product. Circuit diagrams and other information relating to Arasan Chip Systems' products are included as a means of illustrating typical applications. Although the information has been checked and is believed to be accurate, no responsibility is assumed for inaccuracies. Information contained in this document is subject to continuous improvement and development.

Arasan Chip Systems' products are not designed, intended, authorized or warranted for use in any life support or other application where product failure could cause or contribute to personal injury or severe property damage. Any and all such uses without prior written approval of an Officer of Arasan Chip Systems Inc. will be fully at the risk of the customer.

Arasan Chip Systems Inc. disclaims and excludes any and all warranties, including, without limitation, any and all implied warranties of merchantability, fitness for a particular purpose, title, and infringement and the like, and any and all warranties arising from any course or dealing or usage of trade.

This document may not be copied, reproduced, or transmitted to others in any manner. Nor may any use of information in this document be made, except for the specific purposes for which it is transmitted to the recipient, without the prior written consent of Arasan Chip Systems Inc. This specification is subject to change at any time without notice. Arasan Chip Systems Inc. is not responsible for any errors contained herein.

In no event shall Arasan Chip Systems Inc. be liable for any direct, indirect, incidental, special, punitive, or consequential damages; or for loss of data, profits, savings or revenues of any kind; regardless of the form of action, whether based on contract; tort; negligence of Arasan Chip Systems Inc or others; strict liability; breach of warranty; or otherwise; whether or not any remedy of buyers is held to have failed of its essential purpose, and whether or not Arasan Chip Systems Inc. has been advised of the possibility of such damages.

## Restricted Rights

Use, duplication, or disclosure by the Government is subject to restrictions as set forth in FAR52.227-14 and DFAR252.227-7013 et seq. or its successor.

## Copyright Notice

No part of this specification may be reproduced in any form or means, without the prior written consent of Arasan Chip Systems, Inc.

Questions or comments may be directed to:

Arasan Chip Systems Inc.  
2010 North First Street, Suite 510  
San Jose, CA 95131  
Ph: 408-282-1600  
Fax: 408-282-7800  
Email: [sales@arasan.com](mailto:sales@arasan.com)

## Contents

|       |   |    |
|-------|---|----|
| 1     | Introduction .....  | 1  |
| 1.1   | About DSI.....  | 1  |
| 1.2   | Arasan’s Contribution to MIPI .....                           | 1  |
| 1.3   | Arasan’s Total IP Solution .....                              | 1  |
| 2     | MIPI DSI Host IP.....   | 3  |
| 2.1   | Overview.....   | 3  |
| 2.2   | Features.....   | 3  |
| 2.3   | Architecture.....   | 4  |
| 2.3.1 | Functional Description.....                                   | 4  |
| 2.3.2 | Functional Block Diagram .....                                | 5  |
| 2.3.3 | Block Diagram Description .....                               | 5  |
| 2.4   | Pin Diagram .....   | 7  |
| 2.5   | SOC Level Integration .....                                   | 8  |
| 2.5.1 | IP Deliverables .....   | 8  |
| 2.5.2 | Verification Environment .....                                | 8  |
| 3     | MIPI DSI Device IP .....                                      | 10 |
| 3.1   | Overview.....   | 10 |
| 3.2   | Features.....   | 10 |
| 3.3   | Architecture.....   | 11 |
| 3.3.1 | Functional Description.....                                   | 11 |
| 3.3.2 | Functional Block Diagram .....                                | 12 |
| 3.3.3 | Block Description.....  | 12 |
| 3.4   | Pin Diagram .....   | 14 |
| 3.5   | SOC Level Integration .....                                   | 15 |
| 3.5.1 | IP Deliverables .....   | 15 |
| 3.5.2 | Verification Environment .....                                | 16 |
| 4     | D-PHY v1.2 Physical Interface.....                            | 17 |
| 4.1   | Overview.....   | 17 |
| 4.2   | Features.....   | 17 |
| 4.3   | Architecture.....   | 18 |
| 4.3.1 | D-PHY Based Interconnect Architecture.....                    | 18 |
| 4.3.2 | D-PHY Lane Architecture .....                                 | 19 |
| 4.4   | Arasan D-PHY Architecture.....                                | 20 |
| 4.5   | D-PHY Pad Table .....   | 21 |
| 4.5.1 | Functional Description of D-PHY Pads for Clock Lane .....     | 21 |
| 4.5.2 | Functional Description of D-PHY Pads for First Data Lane..... | 21 |

|          |   |           |
|----------|---|-----------|
| 4.5.3    | Functional Description of D-PHY Pads for Second Data Lane .....           | 21        |
| 4.5.4    | Functional Description of D-PHY Pads for Third Data Lane .....            | 21        |
| 4.5.5    | Functional Description of D-PHY Pads for Fourth Data Lane .....           | 22        |
| 4.5.6    | Power Pads .....  | 22        |
| 4.5.7    | Functional Description of Trim Bits .....                                 | 22        |
| 4.5.8    | Functional Description of Clock and Reset Unit Input .....                | 23        |
| 4.5.9    | Functional Description of Data PPI Signals Common to all Data Lanes ..... | 23        |
| 4.5.10   | Functional Description of Clock PPI's Escape Mode Signals .....           | 23        |
| 4.5.11   | Functional Description of Clock PPI's Control Signals.....                | 24        |
| 4.5.12   | Functional Description of Clock PPI's High Speed Interface Signals .....  | 25        |
| 4.5.13   | Functional Description of Data PPI's Escape Mode Signals .....            | 26        |
| 4.5.14   | Functional Description of Data PPI's Control Signals.....                 | 27        |
| 4.5.15   | Functional Description of Side Band Signals.....                          | 28        |
| 4.5.16   | Functional Description of DFT Signals .....                               | 28        |
| 4.5.17   | D-PHY UI Parameter Count Signals.....                                     | 29        |
| 4.5.18   | A-BIST Related Signals .....  | 29        |
| 4.6      | Hard Macro Deliverables .....   | 30        |
| <b>5</b> | <b>Services &amp; Support .....</b>                                       | <b>31</b> |
| 5.1      | Global Support.....   | 31        |
| 5.2      | Arasan Support Team .....   | 31        |
| 5.3      | Professional Services & Customization.....                                | 31        |
| 5.4      | The Arasan Porting Engine .....   | 31        |
| 5.5      | Pricing & Licensing.....  | 31        |

## Tables

|           |   |    |
|-----------|---|----|
| Table 1:  | Functional Description of D-PHY Pads for Clock Lanes .....                                | 21 |
| Table 2:  | Functional Description of D-PHY Pads for First Data Lane.....                             | 21 |
| Table 3:  | Functional Description of D-PHY Pads for Second Data Lane .....                           | 21 |
| Table 4:  | Functional Description of D-PHY Pads for Third Data Lane .....                            | 21 |
| Table 5:  | Functional Description of D-PHY Pads for Fourth Data Lane .....                           | 22 |
| Table 6:  | Power Pads .....  | 22 |
| Table 7:  | Ports for Trim_Bits.....  | 22 |
| Table 8:  | Functional Description of Clock and Reset unit Input signals for clock and data PPI ..... | 23 |
| Table 9:  | Functional Description of data PPI signals that are common to all Data Lanes .....        | 23 |
| Table 10: | Functional Description of Clock PPI's High Speed Interface Signals .....                  | 23 |
| Table 11: | Functional Description of Clock PPI's Control Signals.....                                | 24 |
| Table 12: | Functional Description of Data PPI's High Speed Interface signals.....                    | 25 |
| Table 13: | Functional Description of Data PPI's Escape mode Signals .....                            | 26 |
| Table 14: | Functional Description of Data PPI's Control Signals.....                                 | 27 |

Table 15: Functional Description of Side Band Signals.....28

Table 16: Functional Description of DFT Signals .....28

Table 17: D-PHY UI Parameter Count Signals .....29

Table 18: A-BIST Pins .....29

## Figures

Figure 1: Arasan's Total IP Solution .....2

Figure 2: DSI Host Pinout.....7

Figure 3: DSI Host Pinout Continued .....8

Figure 4: Verification Environment of DSI Host IP .....9

Figure 5: DSI Device (Rx) Functional Block Diagram .....12

Figure 6: DSI Device (Rx) Pinout .....14

Figure 7 : DSI Device (Rx) Pinout Continued.....15

Figure 8: Verification Environment of DSI Device IP .....16

Figure 9: MIPI Link Diagram for Four Data Lanes .....18

Figure 10: D-PHY Lane Architecture .....19

Figure 11: Analog and Digital D-PHY Block Diagram .....20

# 1 Introduction

## 1.1 About DSI

The MIPI® Alliance the Display Serial Interface (DSI) dates back to 2005. The Display Serial Interface specification defines protocols between a host processor and peripheral devices using a D-PHY physical interface. The DSI specification builds on existing specifications by adopting pixel formats and command set defined in MIPI Alliance Specifications for Display Pixel Interface 2 (DPI-2) and Display Command Set (DCS).

From a system or software point of view, serialization and deserialization operations should be transparent. The most visible, and unavoidable consequence of transformation to serial data and back to parallel is increased latency for transactions that require a response from the peripheral. For example, reading a pixel from the frame buffer on a display module has a higher latency using DSI than DBI. Another fundamental difference is the host processor's inability during a read transaction to throttle the rate or size of returned data.

## 1.2 Arasan's Contribution to MIPI

Arasan has been a member of MIPI for over ten years. We are active participants in a number of working groups. We work closely with other member customers to ensure compliant implementation of standards based IP.

## 1.3 Arasan's Total IP Solution

Arasan provides a Total IP Solution, which encompasses all aspects of IP development and integration, including analog and digital IP cores, verification IP, software stacks & drivers, and hardware validation platforms. Benefits of Total IP Solution:

- Seamless integration from PHY to Software
- Assured compliance across all components
- Single point of support
- Easiest acquisition process (one licensing source)
- Lowest overall cost including cost of integration
- Lowest risk for fast time to market

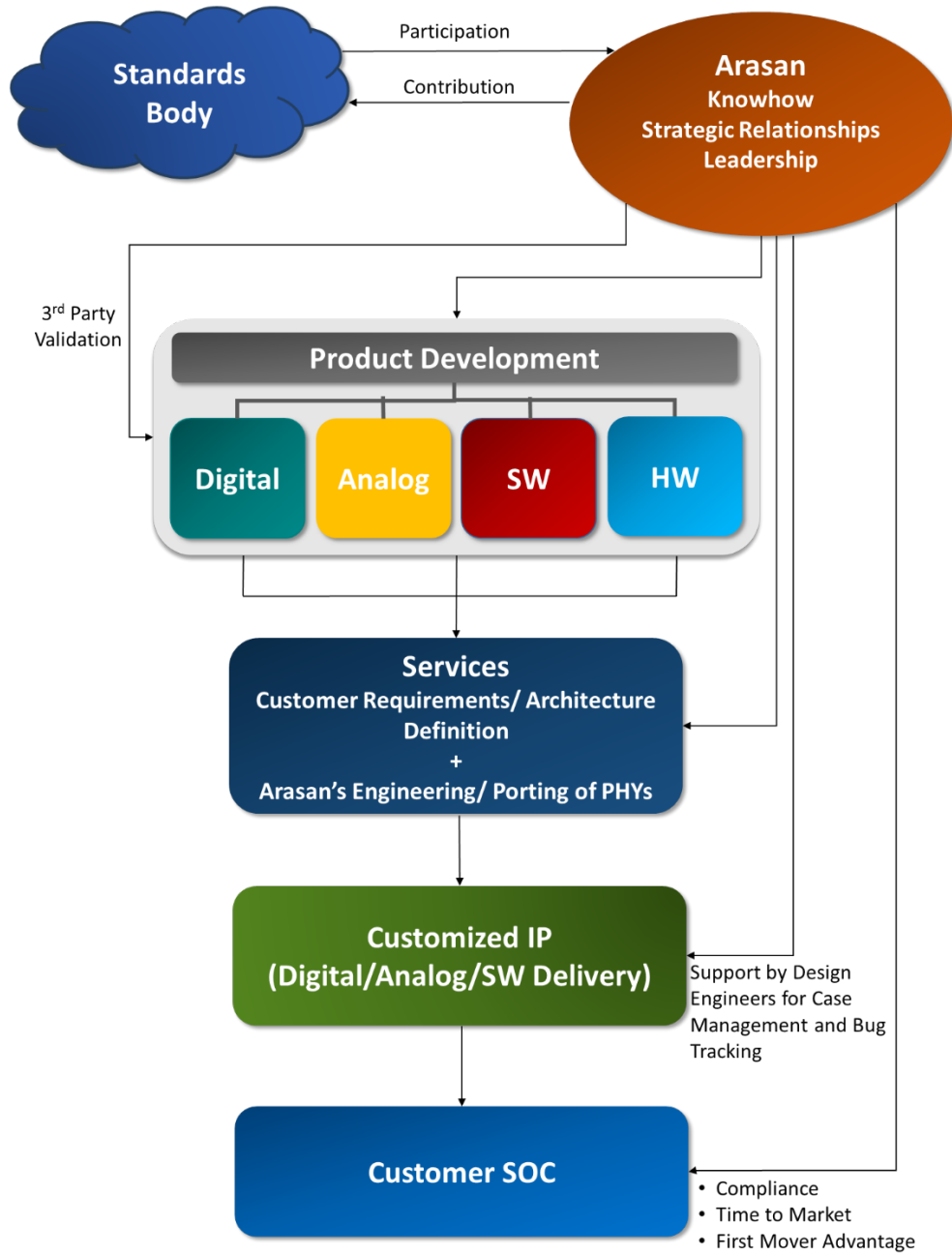

Figure 1: Arasan's Total IP Solution

## 2 MIPI DSI Host IP

### 2.1 Overview

Arasan Chip Systems is a leading SOC IP provider of a complete suite of MIPI compliant IP solutions, which consist of IP cores, verification IP, software stacks and drivers, protocol analyzers, hardware platforms for software development and compliance testing, and optional customization services. The MIPI compliant IP cores are interface building blocks that simplify interconnect architectures in mobile platforms. This leads to smaller footprint, greater interoperability between mobile IP, chips and devices from diverse sources, and lower power and EMI.

This document describes the Arasan IP Core that functions as a MIPI DSI Host Controller, which typically resides in a mobile platform's application processor, and communicates over a D-PHY serial link to a DSI Device in the display panel.

### 2.2 Features

- Compliant with the following MIPI specifications:
  - Display Serial Interface (DSI) version 1.3
  - Display Pixel Interface (DPI-2) version 2.00
  - Display Bus Interface (DBI) version 2.00
  - Display Command Set (DCS) version 1.02
  - D-PHY version 1.2

#### New Features added in V1.2

- Support for compressed image pixel data format
- PPS - picture parameter set - packet for transmitting compression parameters

#### New Features added in V1.3

- Hi-Speed transmit support up to 2.5Gbps per lane
- Deskew support- initial and periodic
- DSI Host-side (display module) interface supports:
  - Connectivity to D-PHY through PPI Interface
  - 1 to 4 data lane
  - Hi-Speed (HS) transmit from 80 Mbps to ~~1.5Gbps~~ 2.5Gbps per lane
  - Low Power (LP) receive/transmit from/to device at 10 Mbps
  - Continuous and stoppable clocks on clock lane
  - Bus turnaround with contention and fault recovery
  - Switching to and from Low Power (LP) and Ultra-low Power (ULPS) modes
  - EOT enable/disable mechanisms
  - Multiple packets per transmission with interleaved data stream
  - Programmable error injection in Verification IP and error detection in design IP

- Flexibility in setting polarity for DPI Interface signals
- Application Processor Connectivity and Video Command Processing
  - DPI or DBI, depending on panel or display unit architecture
  - Generic command support
    - Generic parallel interface for sending and receiving vendor-specific information to and from the display driver logic in the display module
    - Support for all generic read/writes over DBI/Generic interface
- Video Mode supports:
  - Wide range of display resolution and pixel formats
  - Display resolutions: QQVGA, QCIF, QVGA, CIF, VGA, WVGA, XGA, 1080p, QXGA, QSXGA
  - Burst mode and non-burst transfers over DPI interface
- DBI supports:
  - 8/9/16-bit data transfer in DBI Type B interface
  - All DCS commands
- AHB/APB Interface for register configuration and monitoring using programmed IO

## 2.3 Architecture

### 2.3.1 Functional Description

The Arasan DSI Host Controller IP is designed to provide MIPI DSI 1.3 compliant high speed serial connectivity for mobile application processors using 1 to 4 D-PHYs depending on bandwidth needs. Serial connectivity to the display module's DSI device is implemented using 1 to 4 D-PHY's (also available from Arasan), depending on display bandwidth needs. This IP connects to the D-PHY's through the PPI interface.

On the application processor side, Arasan's DSI Host Controller provides the choice of DPI or DBI Interface to a graphics controller. A DBI interface provides downstream support of Types 1 to 3 display modules, and the DPI Interface is needed for Types 2 to 4 displays.

Initial configuration of this IP can be done through programmed IO over the AHB bus, however, other bus interfaces can be provided upon request.

## 2.3.2 Functional Block Diagram

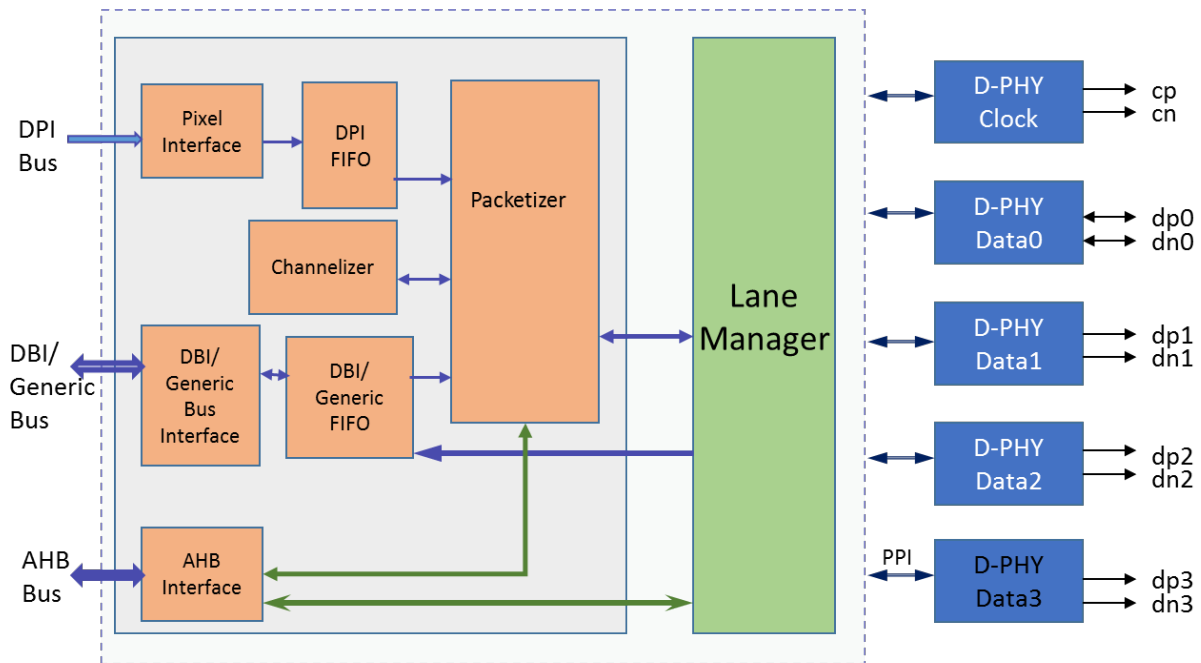

Figure 1: DSI Device (Tx) Functional Block Diagram

## 2.3.3 Block Diagram Description

### 2.3.3.1 Lane Manager

This block communicates through a PPI interface with one to four D-PHY data lanes, depending on the bandwidth needs of an application. The Lane Manager block drives the different states in the D-PHY's like ULPS (Ultra-Low Power State), HS (High Speed) and LP (Low Power). It receives the data from the Packetizer module and distributes across the D-PHY data lanes based on the programmed lane count.

It has timers like high speed transmit timeout, low speed reception timers, and turnaround timeout counters to recover itself from fault mode conditions, and device reset timers for recovery from contentions.

In LP mode, this block is responsible for sending and receiving the trigger messages, and receiving the generic/DCS read response data in short or long packet formats. For incoming LP mode packets, this block manages ECC and CRC checking.

### 2.3.3.2 Channelizer

The Channelizer utilizes the Blanking and Low Power (BLLP) interval during DPI transmits to interleave DBI/Generic transfers during those times. This results in extremely efficient DSI bandwidth utilization.

### **2.3.3.3 Packetizer**

Depending on the packet information registered in the control FIFO in the DBI/Generic Bus Interface, short packets or headers of long packets are generated and transmitted by the Packetizer. For long packets, data from the Data FIFO is appended, the byte length of which is referenced in the control FIFO.

Depending on the signalling in the DPI Interface and the parameters programmed in its registers, either short or long packets are generated and transmitted. ECC is generated and added for short packets and headers of long packets. For long packets, pixels that are gathered in a DPI Data FIFO are appended as payloads of long packets, along with a CRC value calculated by the Packetizer.

### **2.3.3.4 DPI FIFO and Pixel Interface**

A pixel-to-byte converter in the Pixel Interface converts the incoming 16, 18 or 24-bit pixel data to byte format and stores it in DPI FIFO, and notifies the Packetizer. A 2048 x32-bit DPRAM is used for line buffering.

### **2.3.3.5 DBI/Generic FIFO and Bus Interface**

These blocks parse and classify the incoming DCS/generic commands as read and write commands under various categories. The read commands are passed on to the peripherals and read responses are sent back to the DBI interface. Commands that involve a huge data write data transfer are converted into DCS/generic long write commands and sent by the Packetizer to the Lane Manager as packets.

### **2.3.3.6 AHB Slave Interface**

This block allows a processor to configure the IP through programmed IO, and provides for the IP to provide status information to the processor using interrupts.

## 2.4 Pin Diagram

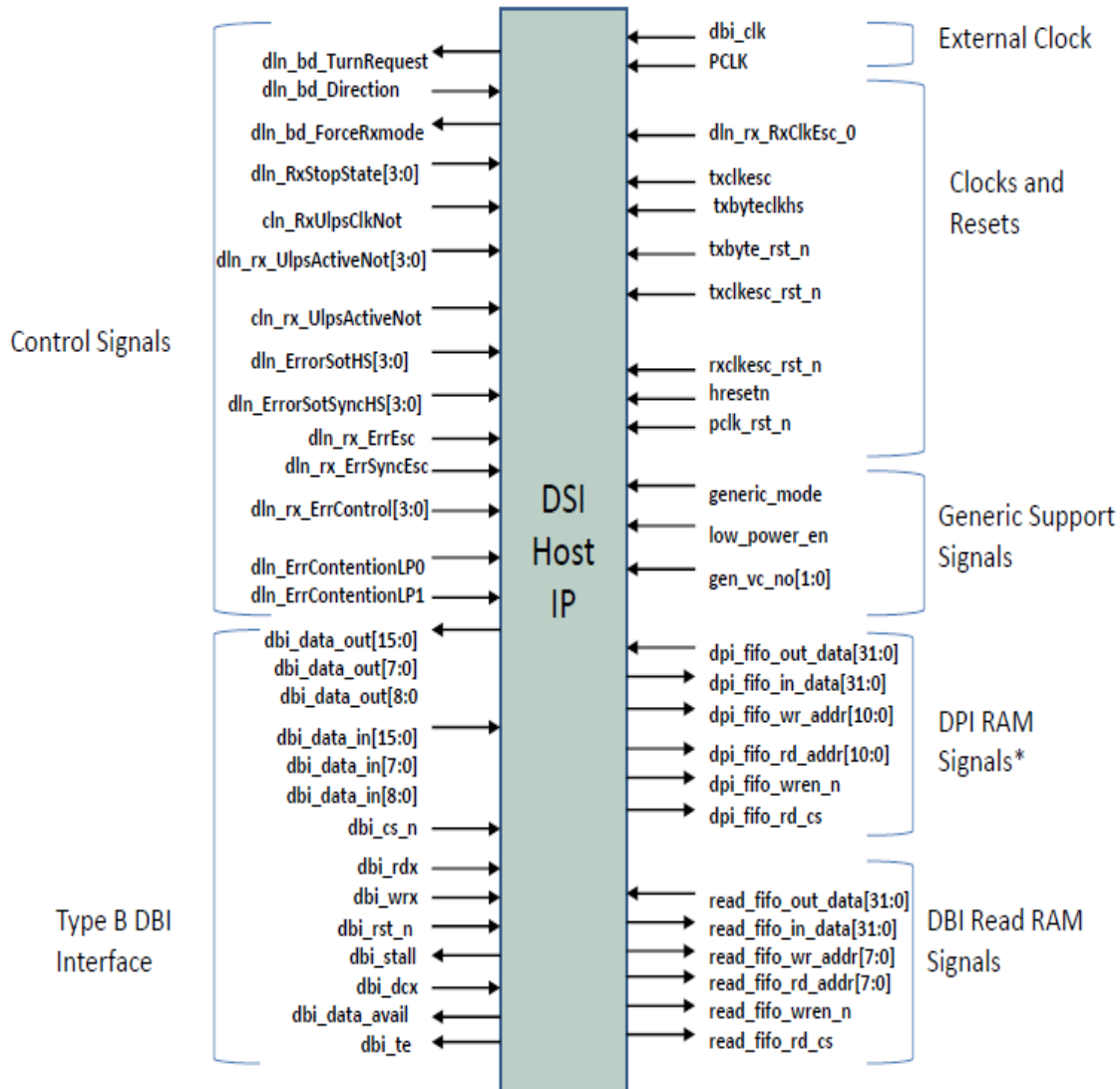

Figure 2: DSI Host Pinout

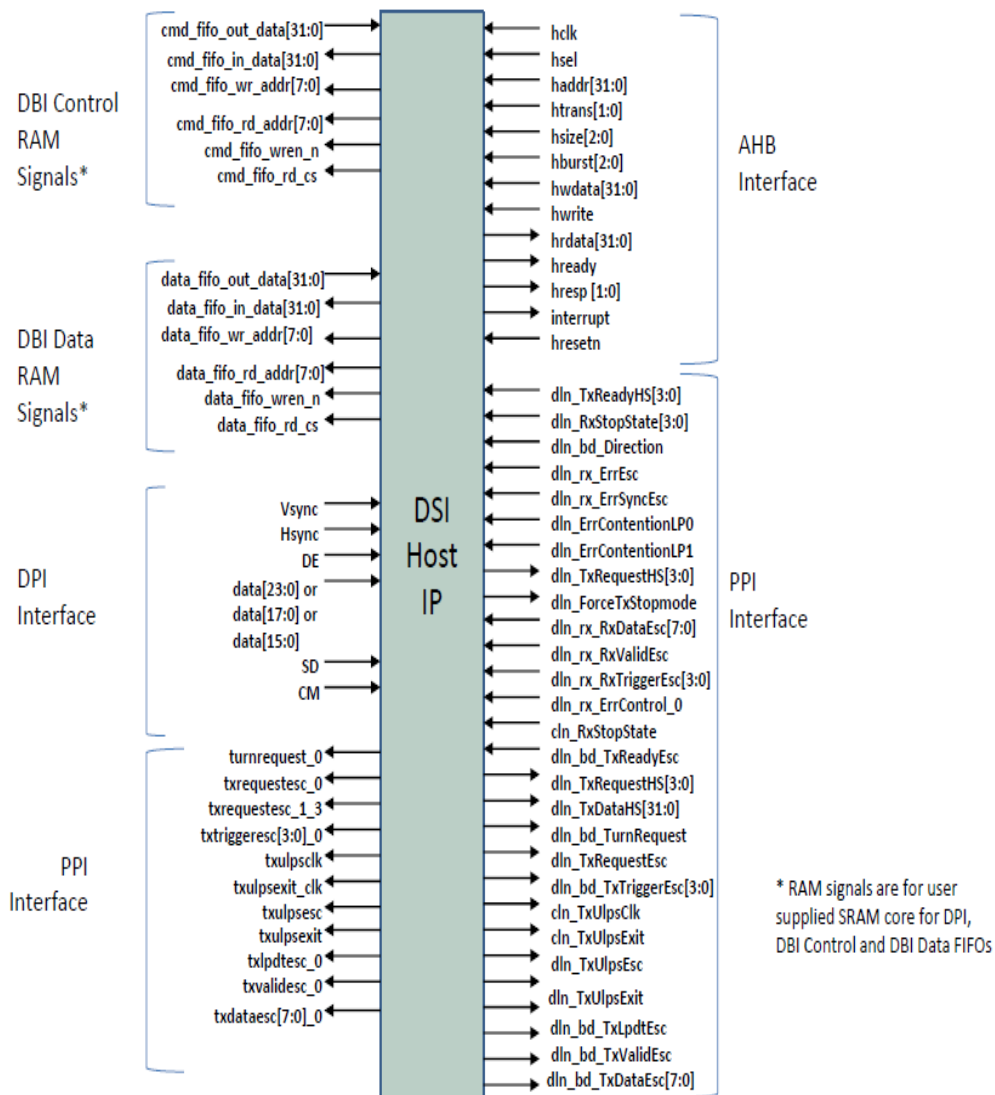

Figure 3: DSI Host Pinout Continued

## 2.5 SOC Level Integration

### 2.5.1 IP Deliverables

- Verilog HDL of the IP Core
- User guide
- Gate count estimates available upon request
- Synthesis scripts

### 2.5.2 Verification Environment

- Comprehensive suite of simulation tests for ease of SOC integration
- Verification components and test files provided
- Verification environment and test suite well documented

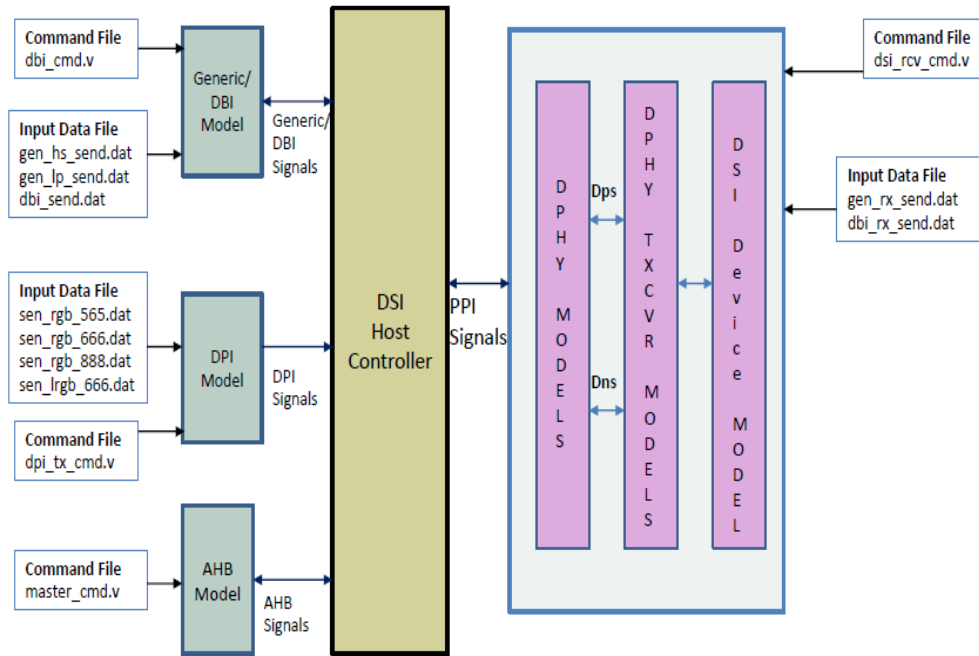

Figure 4: Verification Environment of DSI Host IP

## 3 MIPI DSI Device IP

### 3.1 Overview

Arasan Chip Systems is a leading SOC IP provider of a complete suite of MIPI compliant IP solutions, which consist of IP cores, verification IP, software stacks and drivers, protocol analyzers, hardware platforms for software development and compliance testing, and optional customization services. The MIPI compliant IP cores are interface building blocks that simplify interconnect architectures in mobile platforms. This leads to smaller footprint, greater interoperability between mobile IP, chips and devices from diverse sources, and lower power and EMI.

This document describes the Arasan IP Core that functions as a MIPI DSI Device Controller, which typically resides in a mobile platform's display panel, and communicates over a D-PHY serial link to a DSI Host in the applications processor.

### 3.2 Features

- Compliant with the following MIPI specifications
  - Display Serial Interface (DSI) version 1.3
  - Display Pixel Interface (DPI-2) version 2.00
  - Display Bus Interface (DBI) version 2.00
  - Display Command Set (DCS) version 1.02
  - D-PHY version 1.2

#### New Features added in V1.2

- Support for compressed image pixel data format
- PPS - picture parameter set - packet for transmitting compression parameters

#### New Features added in V1.3

- Hi-speed receive from 80Mbps to 2.5Gbps per lane
- Deskew support- initial and periodic
- DSI Device-side interface supports:
  - Connectivity to D-PHY through PPI Interface
  - 1 to 4 data lane
  - Hi-Speed (HS) receive from 80 Mbps to 2.5Gbps per lane
  - Low Power (LP) receive/transmit from/to host at 10 Mbps
  - Continuous and stoppable clocks on clock lane
  - Bus turnaround with contention and fault recovery
  - Switching to and from Low Power (LP) and Ultra-low Power (ULPS) modes
  - EOT, ECC, and CRC enable/disable mechanisms
  - Multiple packets per transmission with interleaved data stream

- Acknowledge packets and trigger messages
- Programmable error injection in Verification IP and error detection in design IP
- Display Panel Connectivity and video/command processing supports:
  - DPI or DBI, depending on panel or display unit architecture
  - Generic command
  - Generic parallel interface for sending and receiving vendor-specific information to and from the display driver logic in the display module
  - All generic read/writes over DBI/Generic interface
- Video Mode supports:
  - Wide range of display resolution and pixel formats
  - Display resolutions: QQVGA, QCIF, QVGA, CIF, VGA, WVGA, XGA, 1080p, QXGA, QSXGA
  - Burst mode and non-burst transfers over DPI interface
- DBI supports:
  - 8/9/16-bit data transfer in DBI Type B interface
  - All DCS commands
- AHB Interface for register configuration and monitoring using programmed IO

## 3.3 Architecture

### 3.3.1 Functional Description

The Arasan DSI Device Controller IP is designed to provide MIPI DSI 1.3 compliant high speed serial connectivity for mobile display modules with Type 1 to 4 architectures. Serial connectivity to the mobile applications processor's DSI host is implemented using 1 to 4 D-PHY's (also available from Arasan), depending on display bandwidth needs. This IP connects to the D-PHY's through the PPI interface.

Display modules consist of display driver logic driving display signals onto a display device or panel. On the display driver side, Arasan's DSI Device Controller provides the DBI Interface for Types 1 to 3 display modules and the DPI Interface for Types 2 to 4 displays.

Initial configuration of this IP can be done through programmed IO over the AHB bus, however, other bus interfaces can be provided upon request.

### 3.3.2 Functional Block Diagram

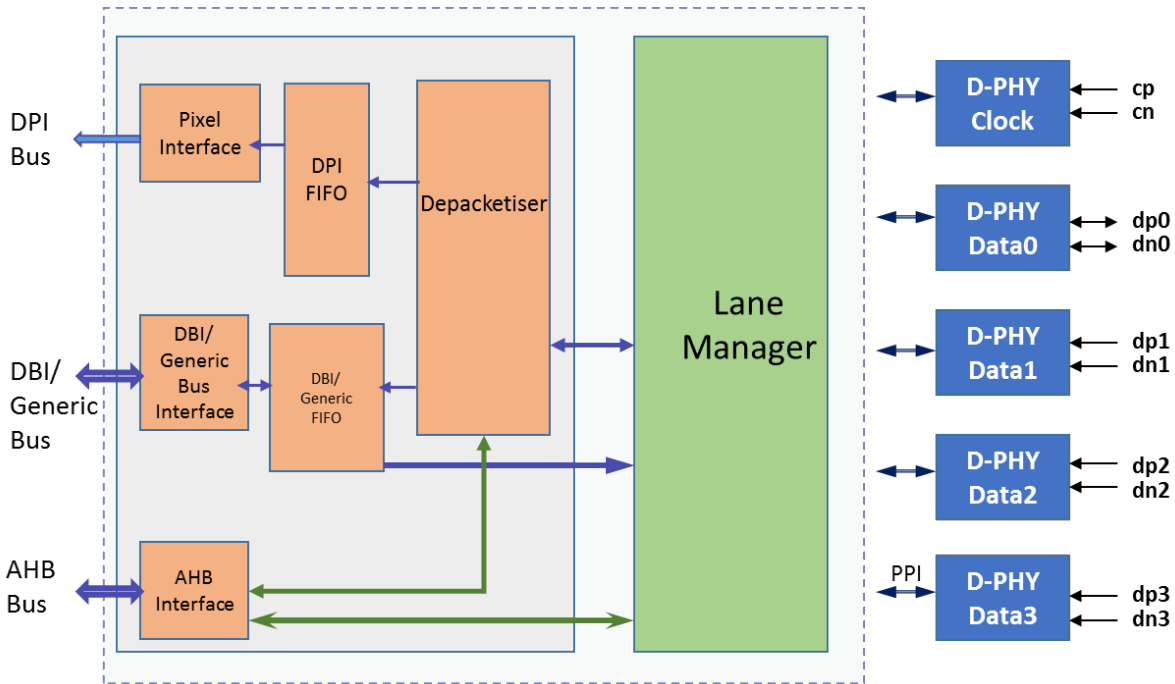

Figure 5: DSI Device (Rx) Functional Block Diagram

### 3.3.3 Block Description

#### 3.3.3.1 Lane Manager

This block communicates through a PPI interface with one to four D-PHY data lanes, depending on the bandwidth needs of an application. The Lane Manager block detects the different states of the D-PHY's like ULPS (Ultra-Low Power State), HS (High Speed) and LP (Low Power). It collects incoming bytes of data from the D-PHY lanes at every clock edge based on programmed lane count and forwards them to the Depacketizer module. It is also responsible for contention and error detection and response for all incoming packets.

In LP mode, this block is responsible for sending trigger messages, acknowledgment packets and generic/DCS read response data in short or long packet formats. For outgoing LP mode packets, this block manages ECC and CRC generation.

#### 3.3.3.2 Depacketizer

From the DSI data type in the Data Identifier of the incoming packet, the Depacketizer determines whether the incoming packet is short or long. From the incoming long packets, the Depacketizer separates out the header, footer and payload and forwards each of them to the appropriate protocol layer blocks. The checksum value for long packet payloads is calculated and compared with received CRC and entered in the register set for further processing. Short packets and headers for long packets are corrected for 1-bit errors.

### 3.3.3.3 DPI FIFO and Pixel Interface

This path is selected in video mode and is unidirectional. Display sync event timing information originates as short packets from the DSI host. Upon receiving them, the Pixel Interface converts those to display-related control signals, such as horizontal and vertical sync and blanking intervals. Payload bytes extracted by the Depacketizer from long packets received in HS mode from the DSI host are sent through the DPI FIFO to the Pixel Interface block, which converts them to pixels and sends to the display panel through the DPI bus.

### 3.3.3.4 DBI/Generic FIFO and Bus Interface

This path is selected in command mode and is bidirectional. Long packets and short packets received from the Depacketizer contain the commands for the off-chip display module that implements the Display Command Set. For DCS or Generic Read commands, the number of data bytes collected for DBI read operations is based on the maximum return packet size settings, and forwarded to the Lane Manager to encapsulate within a packet structure, as described above.

### 3.3.3.5 AHB Slave Interface

This block allows a processor to configure the IP through programmed IO, and provides for the IP to provide status information to the processor using interrupts.

### 3.4 Pin Diagram

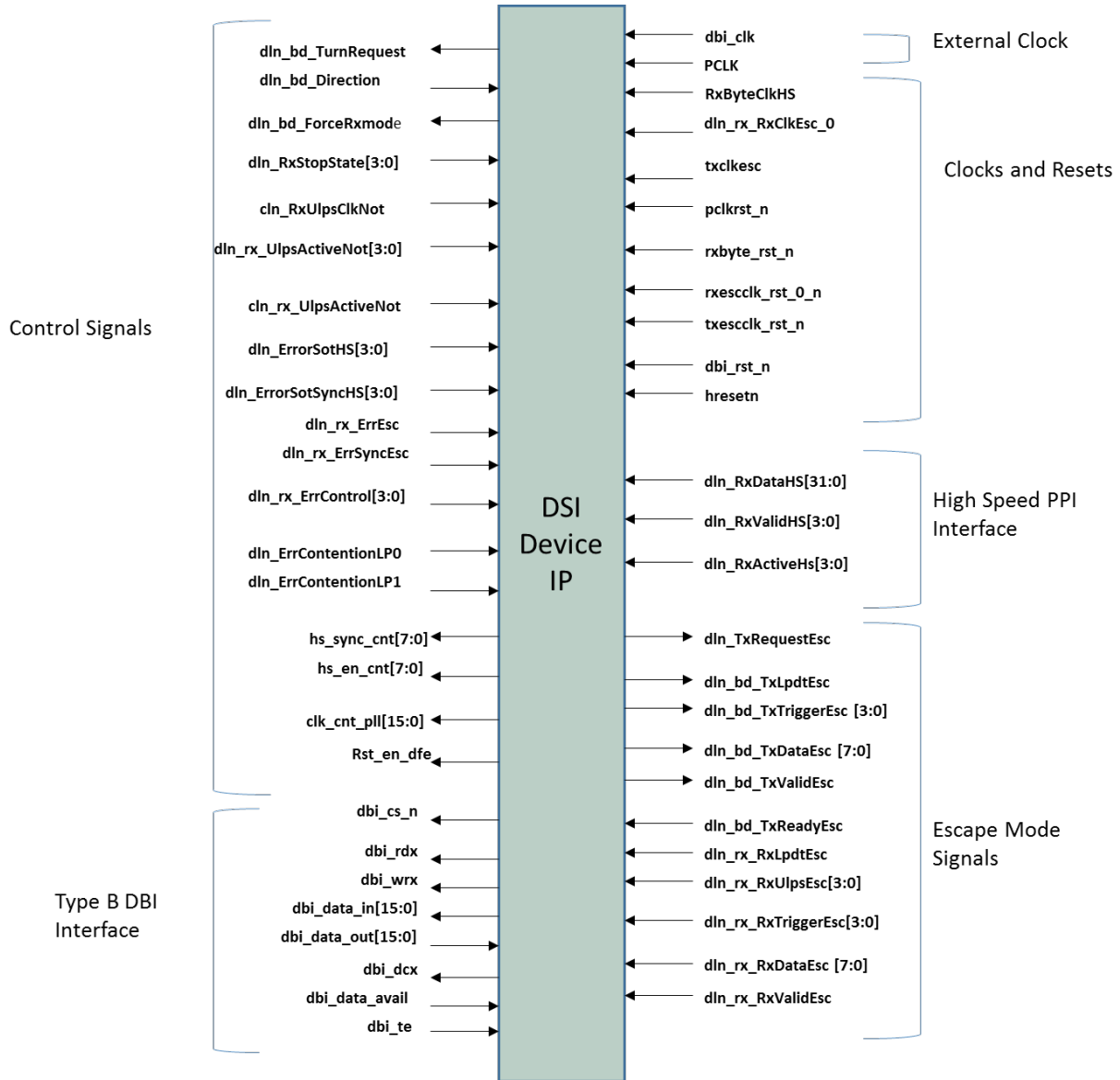

Figure 6: DSI Device (Rx) Pinout

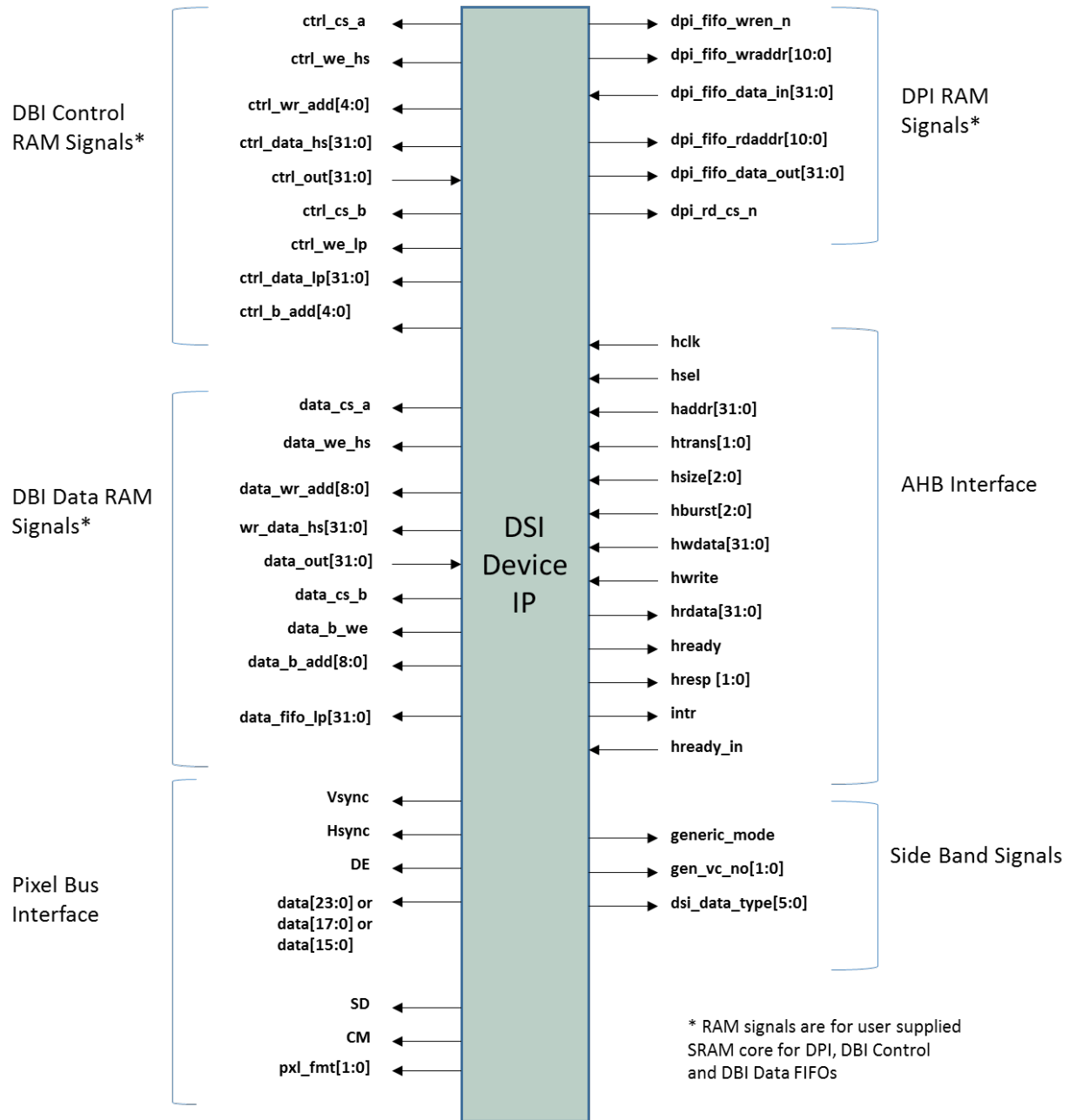

Figure 7 : DSI Device (Rx) Pinout Continued

## 3.5 SOC Level Integration

### 3.5.1 IP Deliverables

- Verilog HDL of the IP Core
- User guide
- Gate count estimates available upon request
- Synthesis scripts

### 3.5.2 Verification Environment

- Comprehensive suite of simulation tests for ease of SoC integration
- Verification components and test files provided
- Verification environment and test suite well documented

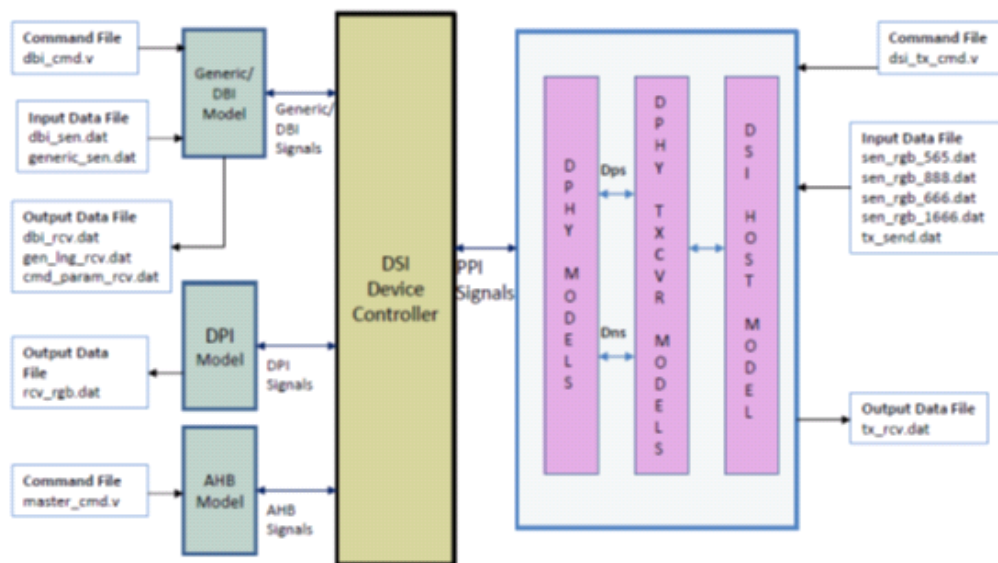

Figure 8: Verification Environment of DSI Device IP

## 4 D-PHY v1.2 Physical Interface

### 4.1 Overview

To address the explosive growth in the mobile industry, the Mobile Industry Processor Interface (MIPI®) Alliance was created to define and promote open standards for interfaces to mobile application processors. D-PHY is the physical layer specified for several of the key protocols within the MIPI® family of specifications.

The Arasan D-PHY IP core is fully compliant to the D-PHY specification version 1.2. It supports the MIPI® Camera Serial Interface (CSI-2) and Display Serial Interface (DSI) protocols. It is a universal PHY that can be configured as a transmitter, receiver or transceiver. The D-PHY consists of an analog front end to generate and receive the electrical level signals, and a digital back end to control the I/O functions.

The Arasan D-PHY provides a point to point connection between master and slave or host and device that comply with a relevant MIPI® standard. A typical configuration consists of a clock lane and 1-4 data lanes. The master/host is primarily the source of data and the slave/device is usually the sink of data. The D-PHY lanes can be configured for unidirectional or bidirectional lane operation, originating at the master and terminating at the slave. It can be configured to operate as a master or as a slave. The D-PHY link supports a high speed (HS) mode for fast data traffic and a low power (LP) mode for control transactions. In HS mode, the low swing differential signal is able to support data transfers from 80 Mbps to 2.5 Gbps. In LP mode all wires operate as a single ended line capable of supporting 10 Mbps asynchronous data communications.

The Arasan D-PHY IP core implements the PPI interface recommended by the MIPI® working groups to easily interface to the required protocols.

### 4.2 Features

- Compliant to MIPI Alliance Standard for D-PHY specification Version 1.2. Supports:
- Synchronous transfer at high speed mode with a bit rate of 80-1500 Mb/s
- Asynchronous transfer at low power mode with a bit rate of 10 Mb/s
- Spaced one hot encoding for Low Power [LP] data
- One byte buffer housed inside the core for both data-out and data-in paths.
- One clock lane and up to four data lanes
- Error detection mechanism for sequence errors and contentions
- Transfer of data in high speed mode
- Ultra low power mode, high speed mode and escape mode.
- Contention detection and turnarounds
- Clock divider unit to generate clock for parallel data reception and transmission from and to the PPI unit.

- Activation and disconnection of high speed terminators for reception and transmission.
- Standard PHY transceiver compliant to MIPI Specification
- Standard PPI interface compliant to MIPI Specification.
- Clock lane unidirectional communication
- On-chip clock generation configurable for either transmitter or a receiver
- Testability for Tx, Rx and PLL
- Configurability of PHY as a master or slave
- Core structured to increase the number of data lanes
- High speed mode in Forward communication

## 4.3 Architecture

### 4.3.1 D-PHY Based Interconnect Architecture

Physical connectivity between a master and slave component requires a clock lane and, depending on bandwidth needs, one to four data lanes. To support this, a D-PHY has a Clock Lane Module, and one to four Data Lane Modules. Each of these D-PHY Lane Modules communicates via a differential signal pair to a complementary part on the other side of the Lane Interconnect.

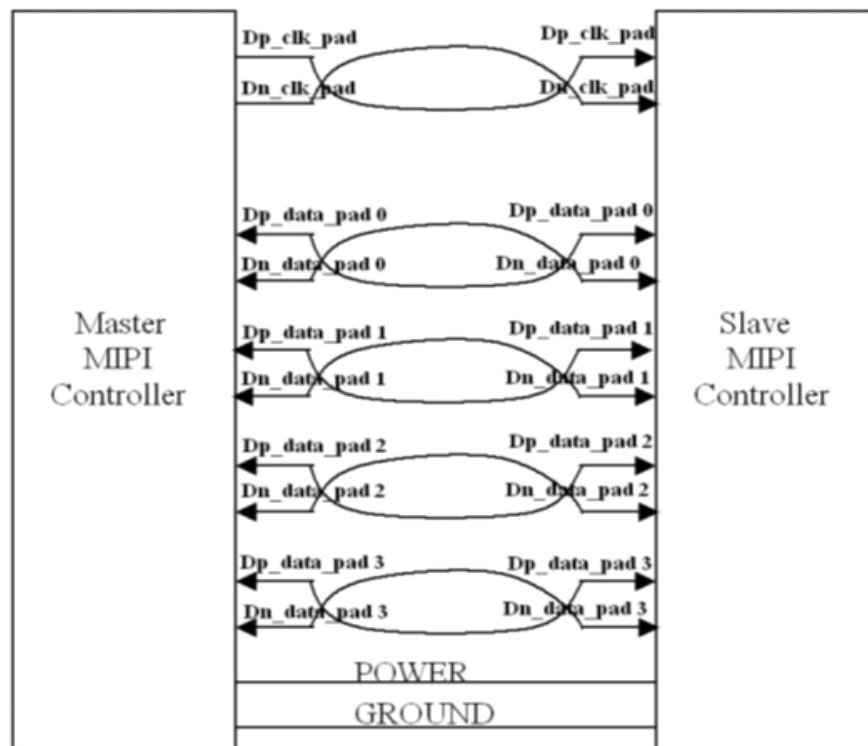

Figure 9: MIPI Link Diagram for Four Data Lanes

### 4.3.2 D-PHY Lane Architecture

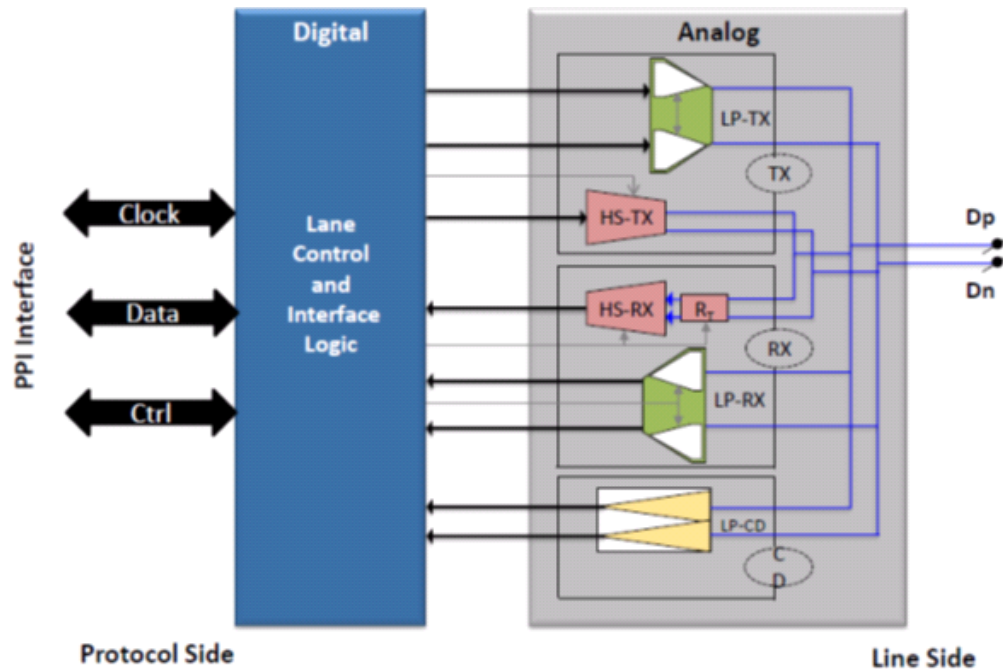

Figure 10: D-PHY Lane Architecture

#### 4.3.2.1 Lane

Each Lane Module has a control and interface logic unit and a transceiver portion to handle differential High-Speed functions utilizing both interconnect wires simultaneously, single-ended Low-Power functions operating on each of the interconnect wires individually and a low power contention detector. The I/O functions are controlled by a Lane Control and Interface Logic block.

#### 4.3.2.2 Signaling

High-Speed signals have a low voltage swing of 200 mV, while Low-Power signals have a large swing of 1.2V. High-Speed functions are used for High-Speed Data traffic. The Low-Power functions are mainly used for control and can have data transfer support.

#### 4.3.2.3 Link

Each link has a Master and a Slave side. The Master provides the High-Speed DDR Clock signal to Clock Lane and is the main data source. The Slave receives the clock signal at the Clock Lane and is the main data sink. This main direction of communication is denoted as the Forward direction. Communication in the opposite direction is called Reverse traffic. Only bi-directional Data Lanes support both forward and reverse communications.

### 4.3.2.4 Lane Control and Interface Logic

It sends and detects start of packet signalling and end of packet signalling on the data lanes. It has a serializer and de-serializer unit to dialog with the PPI / PHY adapter unit. Also it has clock divider unit to source and receive data during parallel data transfers from and to the PPI.

## 4.4 Arasan D-PHY Architecture

The transceiver pins of the Arasan D-PHY are compliant to MIPI's transceivers. The lane control and interface logic unit operates with the clock provided by PPI unit during high speed as well as in low power modes of operation in master mode whereas, a separate low power clock is used in slave mode for low power operations and the received high speed clock is used for high speed data transfers.

In Arasan D-PHY digital IP, both Master and slave modes have state machines to generate sequences for switching to high speed, control mode and ultra low power modes. They have deserializer/serializer unit to convert parallel to serial data and vice-versa.

Slave device has sequence observer state machines to know the modes of operation of the lanes. They have sequence error detectors also.

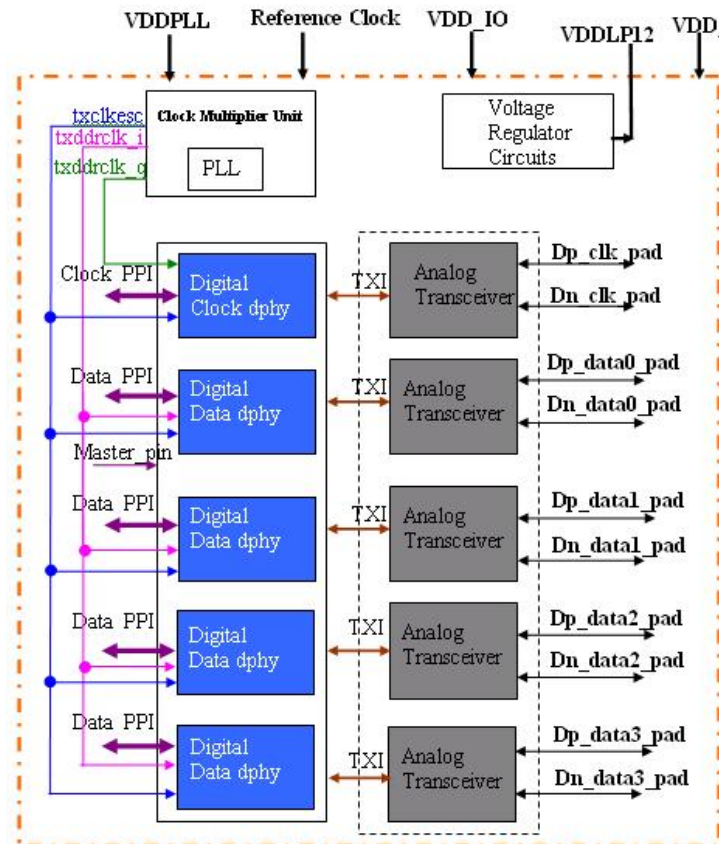

Figure 11: Analog and Digital D-PHY Block Diagram

## 4.5 D-PHY Pad Table

### 4.5.1 Functional Description of D-PHY Pads for Clock Lane

**Table 1: Functional Description of D-PHY Pads for Clock Lanes**

| Pin  | Direction     | Description   |
|------|---------------|---|
| dpck | Bidirectional | Positive polarity of low voltage differential clock signal for transmitter and receiver |
| dnck | Bidirectional | Negative polarity of low voltage differential clock signal for transmitter and receiver |

### 4.5.2 Functional Description of D-PHY Pads for First Data Lane

**Table 2: Functional Description of D-PHY Pads for First Data Lane**

| Pin | Direction     | Description  |
|-----|---------------|--|
| dp0 | Bidirectional | Positive polarity of low voltage differential data signal for transmitter and receiver |
| dn0 | Bidirectional | Negative polarity of low voltage differential data signal for transmitter and receiver |

### 4.5.3 Functional Description of D-PHY Pads for Second Data Lane

**Table 3: Functional Description of D-PHY Pads for Second Data Lane**

| Pin | Direction     | Description  |
|-----|---------------|--|
| dp1 | Bidirectional | Positive polarity of low voltage differential data signal for transmitter and receiver |
| dn1 | Bidirectional | Negative polarity of low voltage differential data signal for transmitter and receiver |

### 4.5.4 Functional Description of D-PHY Pads for Third Data Lane

**Table 4: Functional Description of D-PHY Pads for Third Data Lane**

| Pin | Direction     | Description  |
|-----|---------------|--|
| dp2 | Bidirectional | Positive polarity of low voltage differential data signal for transmitter and receiver |
| dn2 | Bidirectional | Negative polarity of low voltage differential data signal for transmitter and receiver |

### 4.5.5 Functional Description of D-PHY Pads for Fourth Data Lane

**Table 5: Functional Description of D-PHY Pads for Fourth Data Lane**

| Pin | Direction     | Description  |
|-----|---------------|--|
| dp3 | Bidirectional | Positive polarity of low voltage differential data signal for transmitter and receiver |
| dn3 | Bidirectional | Negative polarity of low voltage differential data signal for transmitter and receiver |

### 4.5.6 Power Pads

**Table 6: Power Pads**

| Pin      | Type  | Direction | Description                                |
|----------|-------|-----------|--|
| VDD_clk  | Power | InOut     | Power pad for Clock lane                   |
| VSS_clk  | Power | InOut     | Ground pad for Clock lane                  |
| VDD_d0d1 | Power | InOut     | Power pad for Data lane 0 and Data lane1   |
| VSS_d0d1 | Power | InOut     | Ground pad for Data lane 0 and Data lane1  |
| VDD_d2d3 | Power | InOut     | Power pad for Data lane 2 and Data lane 3  |
| VSS_d2d3 | Power | InOut     | Ground pad for Data lane 2 and Data lane 3 |
| VDDD     | Power | InOut     | Power pad for DFE                          |
| VSSD     | Power | InOut     | Ground pad for DFE                         |
| VDDL12   | Power | InOut     | Power pad for Low power blocks             |

### 4.5.7 Functional Description of Trim Bits

**Table 7: Ports for Trim\_Bits**

| Pin          | Direction | Description        |
|--------------|-----------|--------------------|
| trim_0[31:0] | Input     | Trim bits for DPHY |
| trim_1[31:0] | Input     | Trim bits for DPHY |
| trim_2[31:0] | Input     | Trim bits for DPHY |
| trim_3[31:0] | Input     | Trim bits for DPHY |

## 4.5.8 Functional Description of Clock and Reset Unit Input

**Table 8: Functional Description of Clock and Reset unit Input signals for clock and data PPI**

| Pin              | Direction | Description   |
|------------------|-----------|---|
| TxCkEsc          | Input     | Escape mode Transmit Clock. This clock is directly used to generate escape sequences. The period of this clock determines the symbol time for low power signals. This is also the input reference clock for the PLL |
| enable [ Reset ] | Input     | Active Low system reset to the module.  |

## 4.5.9 Functional Description of Data PPI Signals Common to all Data Lanes

**Table 9: Functional Description of data PPI signals that are common to all Data Lanes**

| Pin                      | Direction | Description   |
|--------------------------|-----------|---|
| dIn_bd_ForceRxmode       | Input     | Force Lane Module Into Receive mode / Wait for Stop state. This signal forces the state machine into RX mode.     |
| dIn_ForceTxStopmode[3:0] | Input     | Force Lane Module Into Transmit mode / Generate Stop state. This signal forces STOP signal on the transmit lines. |

## 4.5.10 Functional Description of Clock PPI's Escape Mode Signals

**Table 10: Functional Description of Clock PPI's High Speed Interface Signals**

| Pin             | Direction | Description   |
|-----------------|-----------|---|
| cln_TxRequestHS | Input     | High-Speed Transmit Request and Data Valid for clock lane.<br>For clock Lanes, this active high signal causes the lane module to begin transmitting a high-speed clock.   |
| cln_RxActiveHS  | Output    | Receiver Clock Active.<br>This asynchronous, active high signal indicates that a clock Lane is receiving a DDR clock signal   |
| TxByteClkHS     | Output    | High-Speed Transmit Byte Clock.<br>This is used to synchronize PPI signals in the High-Speed transmit clock domain. It is recommended that all transmitting Data Lane Modules share one transmitter's byte clock signal. The frequency of byte clock is exactly 1/8 the High-Speed bit rate<br>This is the txbyteclkhs to which all PPI interface is synchronous for transmitter. |

|                       |        |   |
|-----------------------|--------|---|
| RxByteClkHS           | Output | High-Speed Receive Byte Clock.<br>This is used to synchronize signals in the High-Speed receive clock domain. The rxbyteclkhs is generated by dividing the received High-Speed DDR clock<br>This is the byte clock to which all PPI interface is synchronous for receiver.  |
| RxDDRCIkHS_0          | Output | High speed DDR clock used by the receiver.  |
| cln_TxUlpsExit        | Input  | Transmit ULP Exit Sequence for clock lane. This active high signal is asserted when ULP state is active and the protocol is ready to leave ULP state. The PHY leaves ULP state and begins driving Mark- 1 when tx_ulpsactivenot_clk_n becomes deasserted. txulpsexit_clk is synchronous to txclkesc. This signal is ignored when the Lane is not in the ULP State |
| cln_TxUlpsClk         | Input  | To force the clock lane to transmit ULPS sequences in the clock line.   |
| cln_RxUlpsClkNot      | Output | Receive Ultra Low-Power mode on Clock Lane. This active low signal is asserted to indicate that the Clock Lane module has entered the Ultra Low-Power mode. The Lane module remains in this mode with RxUlpsClkNot asserted until a Stop state is detected on the Lane Interconnect   |
| cln_tx_UlpsActive Not | Output | ULP State (not) Active for clock lane. This active low signal is asserted to indicate that the Lane is in ULP state.  |
| cln_rx_UlpsActiveNot  | Output | ULP State (not) Active for clock lane. This active low signal is asserted to indicate that the Lane is in ULP state   |

### 4.5.11 Functional Description of Clock PPI's Control Signals

**Table 11: Functional Description of Clock PPI's Control Signals**

| Pin             | Direction | Description   |
|-----------------|-----------|---|
| cln_Rxstopstate | Output    | Lane is in Stop state for clock lane. This active high signal indicates that the lane module is currently in Stop state. This is valid for both receivers and transmitters. Note that this signal is asynchronous to any clock in the PPI interface |

## 4.5.12 Functional Description of Clock PPI's High Speed Interface Signals

**Table 12: Functional Description of Data PPI's High Speed Interface signals**

| Pin                   | Direction | Description   |
|-----------------------|-----------|---|
| dIn_TxDataHS[31:0]    | Input     | High-Speed Transmit Data for data lane. High-speed data to be transmitted. Data is captured on rising edges of transmitted byte clock.  |
| dIn_TxRequestHS [3:0] | Input     | High-Speed Transmit Request and Data Valid for data lane.<br>A low-to-high transition on txrequesths causes the lane module to initiate a Start-of-Transmission sequence. A high-to-low transition on txrequesths causes the lane module to initiate an End-of- Transmission sequence. For Data Lanes, this active high signal also indicates that the protocol is driving valid data on txdatahs_0 to be transmitted. The lane module accepts the data when both txrequesths and txreadyhs are active on the same rising txbyteclkhs clock edge. The protocol always provides valid transmit data when txdatahs_0 is active. Once asserted, txdatahs remains high until the data has been accepted, as indicated by txreadyhs. txdatahs is only asserted while txrequestesc_0 is low |
| dIn_TxReadyHS [3:0]   | Output    | High-Speed Transmit Ready for data lane. This active high signal indicates that txdatahs_0 is accepted by the lane module to be serially transmitted. txreadyhs_0 is valid on rising edges of transmitted byte clock.   |
| dIn_RxDataHS[31:0]    | Output    | High-Speed Receive Data for data lane.<br>The signal connected to rxdatahs_0 was received first. Data is transferred on rising edges of receiver byte clock.  |
| dIn_RxValidHS[3:0]    | Output    | High-Speed Receive Data Valid for data lane.  |
| dIn_RxActiveHS [3:0]  | Output    | High-Speed Reception Active for data lane.<br>This active high signal indicates that the lane module is actively receiving a high-speed transmission from the lane interconnect.  |
| dIn_RxSyncHS[3:0]     | Output    | Receiver Synchronization Observed for data lane.<br>This active high signal indicates that the Lane module has seen an appropriate synchronization event. In a typical high-speed transmission, rxsynchs_0 is high for one cycle of received byte clock at the beginning of a high-speed transmission when rxactivehs_0 is first asserted, and again for one cycle of received byte clock at the end of a high-speed transmission, just before rxvalidhs_0 returns low.   |

## 4.5.13 Functional Description of Data PPI's Escape Mode Signals

**Table 13: Functional Description of Data PPI's Escape mode Signals**

| Pin                       | Direction | Description  |
|---------------------------|-----------|--|
| dIn_TxRequestEsc [3:0]    | Input     | Escape mode Transmit Request for data lane . txrequestesc_0 is only asserted by the protocol while txrequesths_0 is low.   |
| dIn_TxUlpsExit[3:0]       | Input     | Transmit ULP Exit Sequence for data lane 0. This active high signal is asserted when ULP state is active and the protocol is ready to leave ULP state. The PHY leaves ULP state and begins driving Mark- 1 when ulpsactivenot_0_n becomes deasserted. txulpsexit_0 is synchronous to txclkesc. This signal is ignored when the Lane is not in the ULP State. |
| dIn_TxUlpsEsc[3:0]        | Input     | Escape mode Transmit Ultra Low Power for data lane 0. This active high signal is asserted with txrequestesc to cause the lane module to enter the ultra-low power mode. The lane module remains in this mode until txrequestesc_0 is deasserted. txlpdtesc_0 and all bits of txtriggeresc are low when txulpsesc_0 is asserted.                              |
| dIn_bd_TxLpdtEsc          | Input     | This signal is used to request a low power data transmission entry in the reverse direction.   |
| dIn_bd_TxTriggerEsc [3:0] | Input     | A 4 bit signal that triggers a trigger sequence in the ESC mode in the reverse direction.  |
| dIn_bd_TxDataEsc [7:0]    | Input     | In data mode, the 8-bit data to be transmitted in the reverse direction.   |
| dIn_bd_TxValidEsc         | Input     | A valid signal which qualifies for the data lines.   |
| dIn_bd_TurnDisable        | Input     | To avoid the turn-around request during the lock up situation.   |
| dIn_bd_Direction          | OutPut    | To indicate the direction of the data lane. This signal is used to indicate the current direction of the lane interconnect. When direction_0 =0, the lane is in transmit mode (0=Output). When direction_0 =1, the lane is in receive mode (1=Input).  |
| dIn_bd_TurnRequest        | Input     | This signal is used to request a turn-around operation for a bidirectional lane.   |
| dIn_rx_RxClkEsc [3:0]     | Output    | Escape mode Receive Clock for data lane 0. This signal is used to transfer received data to the protocol during escape mode. This "clock" is generated from the two Low-Power signals in the Lane interconnect. Because of the asynchronous nature of Escape mode data transmission, this "clock" may not be periodic.                                       |

| Pin                       | Direction | Description  |
|---------------------------|-----------|--|
| dln_rx_RxUlpsEsc[3:0]     | Output    | Escape Ultra Low Power (Receive) mode for data lane.<br>This active high signal is asserted to indicate that the lane module has entered the ultra-low power mode. The lane module remains in this mode with rxulpsesc asserted until a Stop state is detected on the lane interconnect. |
| dln_rx_UlpsActiveNot[3:0] | Output    | ULPS signal received on the receiver in the bi-directional lane  |
| dln_bd_TxReadyEsc         | Output    | Ready signal for the transmit data lines in reverse direction.   |
| dln_rx_RxDataEsc[7:0]     | Output    | The low power mode data in the Escape mode.  |
| dln_rx_RxValidEsc         | Output    | The ESC mode valid data.   |
| dln_rx_RxTriggerEsc[3:0]  | Output    | The Trigger mode receiver signal.  |
| dln_rx_RxLpdtEsc          | Output    | The low power data transfer for the first lane   |
| dln_rx_ErrEsc             | Output    | Error on the Escape sequence during receiver   |
| dln_rx_ErrSyncEsc         | Output    | Error in sync esc in the receiver mode.  |

#### 4.5.14 Functional Description of Data PPI’s Control Signals

Table 14: Functional Description of Data PPI’s Control Signals

| Pin                       | Direction | Description  |
|---------------------------|-----------|--|
| dln_RxStopState[3:0]      | Output    | Lane is in Stop state for data lane.<br>This active high signal indicates that the lane module is currently in Stop state. Note that this signal is asynchronous to any clock in the PPI interface.  |
| dln_tx_UlpsActiveNot[3:0] | Output    | ULP State (not) Active for data lane.<br>This active low signal is asserted to indicate that the Lane is in ULP state.   |
| dln_ErrorSotHS[3:0]       | Output    | Start-of-Transmission (SoT) Error for data lane.<br>If the high-speed SoT leader sequence is corrupted, but in such a way that proper synchronization can still be achieved, this error signal is asserted for one cycle of receiver’s byte clock. This is considered to be a "soft error" in the leader sequence and confidence in the payload data is reduced. |
| dln_ErrorSotSyncHS[3:0]   | Output    | Start-of-Transmission Synchronization Error for data lane 0.<br>If the high-speed SoT leader sequence is corrupted   |

| Pin                     | Direction | Description  |
|-------------------------|-----------|--|
|                         |           | in a way that proper synchronization cannot be expected, this error signal is asserted for one cycle of receiver's byte clock. |
| dln_ErrContention LP0   | Output    | The contention error signal on LP0 line.   |
| dln_ErrContention LP1   | Output    | The contention error signal on LP1 line.   |
| dln_rx_ErrControl [3:0] | Output    | Error control in lane 0 during receiver  |

### 4.5.15 Functional Description of Side Band Signals

Table 15: Functional Description of Side Band Signals

| Pin               | Direction | Description   |
|-------------------|-----------|---|
| dln_def_dir       | Input     | Provides the default direction of the bi-directional lane, 1'b1-receive, 1'b0-transmit. |
| dln_dpdnswap[3:0] | Input     | Enable dp dn swap on data lanes 0 to 3 in HS Tx mode.                                   |
| cln_pll_locked    | Output    | PLL locked signal from the Dphy   |

### 4.5.16 Functional Description of DFT Signals

Table 16: Functional Description of DFT Signals

| Pin            | Direction | Description                    |
|----------------|-----------|--------------------------------|
| SCAN_EN        | Input     | Scan mode Enable.              |
| SCAN_CLK       | Input     | Scan clock                     |
| SA_SCAN        | Input     | Stuck-At scan mode.            |
| SCAN_IN        | Input     | Scan input for At-speed scan.  |
| SCAN_OUT       | Output    | Scan output for At-speed scan. |
| DFT_sdi_1 to 6 | Input     | Scan input for At-speed scan.  |
| DFT_sdo_1 to 6 | Output    | Scan output for At-speed scan. |

### 4.5.17 D-PHY UI Parameter Count Signals

Table 17: D-PHY UI Parameter Count Signals

| Pin                   | Type     | Direction | Description   |
|-----------------------|----------|-----------|---|
| dln_cnt_hs_prep[7:0]  | Register | Input     | The period for which HS prepare time should be accommodated for data lane[40ns] |
| dln_cnt_hs_zero[7:0]  | Register | Input     | count [260ns] for Tclock count.   |
| dln_cnt_hs_trail[7:0] | Register | Input     | The period for which HS trailing should be driven for data lane[60ns].          |
| dln_cnt_hs_exit[7:0]  | Register | Input     | The period for which HS exit state should be maintained for data lane[110ns].   |
| dln_rx_cnt[7:0]       | Register | Input     | Counter that controls the assertion of enable on the DPHY for data lane         |
| dln_sync_cnt[7:0]     | Register | Input     | A timeout value used for sync error detector logic for data lane.               |
| dln_cnt_lpx[7:0]      | Register | Input     | Wait time in byte data for the LPX for data lane.                               |
| cln_cnt_hs_trail[7:0] | Register | Input     | Wait time in byte clock for the trailing bits for clock lane[60ns].             |
| cln_cnt_hs_exit[7:0]  | Register | Input     | wait time in byte clock for the exit state for clock lane[110ns]                |
| cln_cnt_lpx[7:0]      | Register | Input     | wait time in byte clock for the LPX for clock lane.                             |
| cln_cnt_prep[7:0]     | Register | Input     | wait time in byte clock for the prepare time for clock lane[40ns]               |
| cln_cnt_zero[7:0]     | Register | Input     | wait time in byte clock for the zero state for clock lane[260ns].               |
| cln_cnt_pll[15:0]     | Register | Input     | The count value which is used for the PLL lock time.                            |
| dln_cnt_lpx[7:0]      | Register | Input     | The period for which the LP state should be driven.                             |

### 4.5.18 A-BIST Related Signals

Table 18: A-BIST Pins

| Pin              | Direction | Description   |
|------------------|-----------|---|
| dln_loop_back    | Input     | Enable A-BIST (loopback BIST)                       |
| bist_seed[7:0]   | Input     | BIST PRBS initiation seed                           |
| bist_force_error | Input     | Signal is used to introduce errors in the BIST run. |

| Pin                               | Direction | Description   |
|-----------------------------------|-----------|---|
| bist_en_esc_lp,<br>bist_en_esc_hs | Input     | Bist mode selection pins<br>00-> Reserved<br>01-> HS Mode<br>10-> LP Mode<br>11-> RxClkEsc Generation |
| bist_err_rx_hs                    | Output    | Error in HS reception   |
| bist_err_rx_hs_sync               | Output    | Error in RX HS sync   |
| bist_err_rx_esc                   | Output    | Error in LP reception   |
| bist_err_rx_esc_<br>sync          | Output    | Error in LP rx sync   |
| bist_done                         | Output    | End of BIST comparison  |

## 4.6 Hard Macro Deliverables

- GDS-II
- CDL netlist for LVS
- LVS reports
- DRC and Antenna reports
- LIB files
- User-guide and integration guides
- LEF
- Scan-inserted netlist for DFT
- Verification Environment with behavioral models

## 5 Services & Support

### 5.1 Global Support

Arasan Chip Systems provide global support to its IP customers. The technical support is not geographically bound to any specific site or location, and therefore our customers can easily get support for design teams that are distributed in several locations at no extra cost.

### 5.2 Arasan Support Team

Our technical support is provided by the engineers who have designed the IP. That is a huge benefit for our customers, who can communicate directly with the engineers who have the deepest knowledge and domain expertise of the IP, and the standard to which it complies.

### 5.3 Professional Services & Customization

At Arasan Chip Systems we understand that no two Application Processors are the same. We realize that often the standard itself needs some tweaks and optimizations to fit your design better. Sometimes, the interface between the IP blocks and your design need some customization. Therefore, we provide professional services and customization to our IP customers. We do not sell our IP blocks as “black box” that cannot be touched. Please contact us for more details on our customization services.

### 5.4 The Arasan Porting Engine

Analog IP blocks, such as eMMC 5.1 HS400 PHY, are designed for a specific Fab and process technology. Arasan’s analog design team, utilizing its deep domain expertise and vast experience, is capable of porting the PHYs into any specific process technology required by the customer. That is “The Arasan Porting Engine”.

### 5.5 Pricing & Licensing

Arasan charges a one-time licensing fee, with no additional royalties. The licensing fee gives the right to use our IP for 1 project. Licensing fee for additional projects, using the same IP, is discounted. We also offer unlimited-use license. For any additional information regarding pricing and licensing – please contact our sales at: [sales@arasan.com](mailto:sales@arasan.com).